

PARAGON PLASTICS, INC.

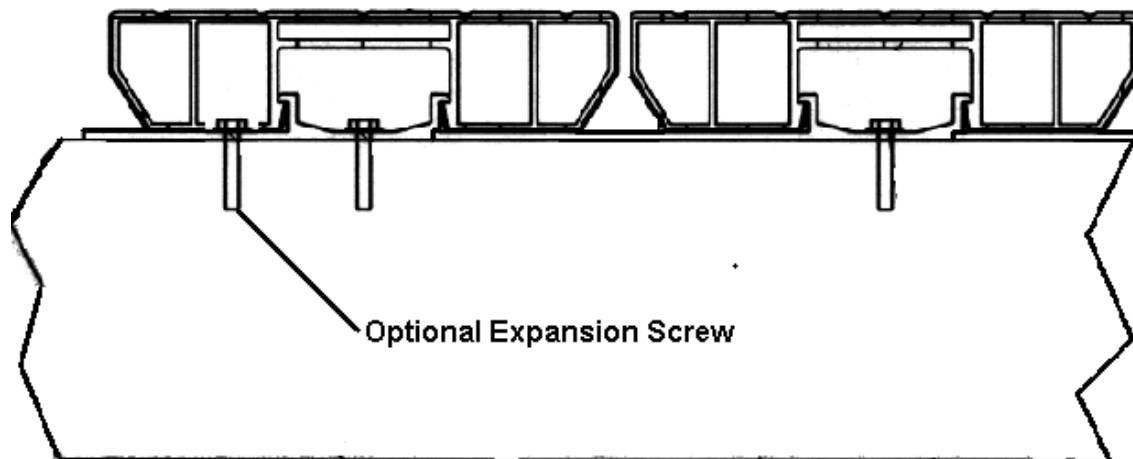

RESIDENTIAL DECKING INSTALLATION INSTRUCTIONS

Please read all the installation instructions before you begin your project.



GENERAL INFORMATION

These instructions are written to familiarize you with the components and tasks before you begin your deck construction project. If you do not understand or feel the project is unclear, we recommend that a licensed contractor perform the work for you. Paragon Plastics, Inc. and its designated agents do not assume any responsibility for Premier Decks which are not installed per the installation instructions contained herein or for Premier Decking component failure, excessive deflection, permanent deformation or other deficiencies due to poor workmanship and/or an inadequately designed or constructed substructure.

Safety is of the utmost importance especially when you are building in or around residential homes. Wear proper clothing and use eye protection as well as utilizing safe, well-maintained tools, equipment and proper procedures.

It is important to remember that Premier Decking must not be used as a primary structural member, such as is needed for load-bearing columns, post, joists, stringers, or beams. Special applications or unusual loading conditions such as a hot tub installation may require an engineering analysis before installation.

To help get started, you may want to purchase a deck planning book available at most local book stores and home improvement centers.

GENERAL INSTRUCTIONS

1. Before beginning construction on your new or replacement deck, remember it is the homeowner's responsibility to check on applicable code requirements and obtain the necessary Building Permits for your geographical area.

2. A well-framed substructure is important. Joists, hardware, and ledgers must be straight, square and level. Adequate blocking between joists should be installed in accordance with good building practices to solidify the framework and eliminate joist warpage. Keep the joists, rim joists and ledgers straight and provide complete support to the wood/vinyl posts. All edges and penetrations shall have adequate blocking to support the decking. If complex shapes are incorporated into the project it is advised to seek professional help for design and layout.
3. When resurfacing a deck, the installer shall completely inspect the foundation, piers, posts, beams, and joists to ensure the adequacy of the substructure. Replace all rotted, damaged, or insect infected material. If you are unable to judge the structural adequacy of the existing substructure, seek the professional opinion of a licensed contractor or structural engineer.
4. All hardware must be weather-resistant. Aluminum track should be installed with a hex drive stainless steel #8 x 1 1/4" screw minimum.

FLEXI-TRAC

- Flexi-Trac is available in a 2'-0" length which contains four premounted flange assemblies. The track is configured with an elongated 90° edge to help align track members and aid in moisture protection for the 2X joist. The under side of the track is configured with a drip edge to aid in moisture protection of the 2X joist. The under side also contains break off lines which can be easily snapped off when the 90° edge portion adjacent the break off line is cut or nipped. The track member can then be bent in half to separate the track into the desired segments. Lay out for other than perpendicular track is more complex and attention to detail must be observed by the installer. For example, if a deck is being installed with planks at 45° angles to the joist, the joist should be spaced no greater than 16" on center.
- Individual flange assemblies are available to simplify installation at difficult angle conditions that regular track members don't remedy easily.

LAYOUT/INSTALLATION

Before proceeding, review Preparing Expansion Joint Joists (see below).

- Establish a control line and mark a point on each end of the deck and then snap an alignment chalk line.
- Place the track end on the control line and fasten down the track with screws at the holes centered at the flange assemble. (4 attachment locations per 2' track). Use recommended # 8X1 1/2 inch stainless steel screws for fastening. Install the track on the remaining joists using the control line for alignment.
- Install the deck planks by placing the recess portion of a plank over the flange assembly while aligning the ends of the plank to the desired location. Step onto the center of the plank with your heel facing the length portion of the plank and listen for the "snap" sound. Continue "snapping" down the length of the plank until all flanges are fully engaged to the deck plank.
- Subsequent track to be installed in a similar manner as described above.
- The first deck plank against the house may need to be ripped or coped lengthwise in order to match the contour of the house. Approximately 1/4" may be cut from the deck plank (inside of the deck plank there are internal support webs starting 1/4" from the plank edge that should **not** be cut away).

LAST ROW

- For the last row, it may be necessary to cut the track to length.
- If the last row is a partial-width plank, only the outside edge (approx. 1/4") of the deck plank should be ripped. Shorten the final track to match substructure. **Note:** Ripped planks should be covered with appropriate trim and **not** be used where foot traffic is present.

EXPANSION JOINTS

- When the deck requires more than one plank per row an H-channel should be used as an expansion joint/trim strip.
- Determine the number of expansion joints by the length of the deck. For example, if your deck is 36' long you may use 3 deck planks 12' long. This requires 2 expansion joints. For ease of installation, install the middle 12' deck section first. This allows for the H-channels to be placed on both ends of the completed middle section.

PREPARING EXPANSION JOINT JOISTS

- On both sides of the joist used for the expansion joint, a 2X4 minimum pressure treated joist should be added by nailing the 2X4 to joist with 16 D common galvanized nails on 16" centers. Make sure the tops of the added joists are flush with the top of the middle joist.
- The tracks at the expansion joint are placed on the two added joists previously installed and the H-channel strip will be located over the middle joist. **Note:** The added joists must extend down the full length of the expansion joint. Tracks are required on the added joists on both sides of the H-channel. The H-channel is an expansion joint trim strip and **not** a strip to be used as a source for structural attachment. It is also recommended that the joist bay on either side of the newly prepared expansion joint joists be no greater than 16" from the H channel. The spacing reduction at the expansion joint will insure added support reducing deflection at the seam.
- Install the track on the working side of the H-channel expansion joint and "snap" the deck in place. Install the H-channel on the completed side of the deck next. Fasten the H-channel down before the opposite side of deck is installed. The H-channel can be fastened with a screw to the middle joist between the deck planks 1'-0" on centers minimum. Finally, the tracks on the added joist of the attachment side of the H-channel are installed and the deck planks are "snapped" into place.

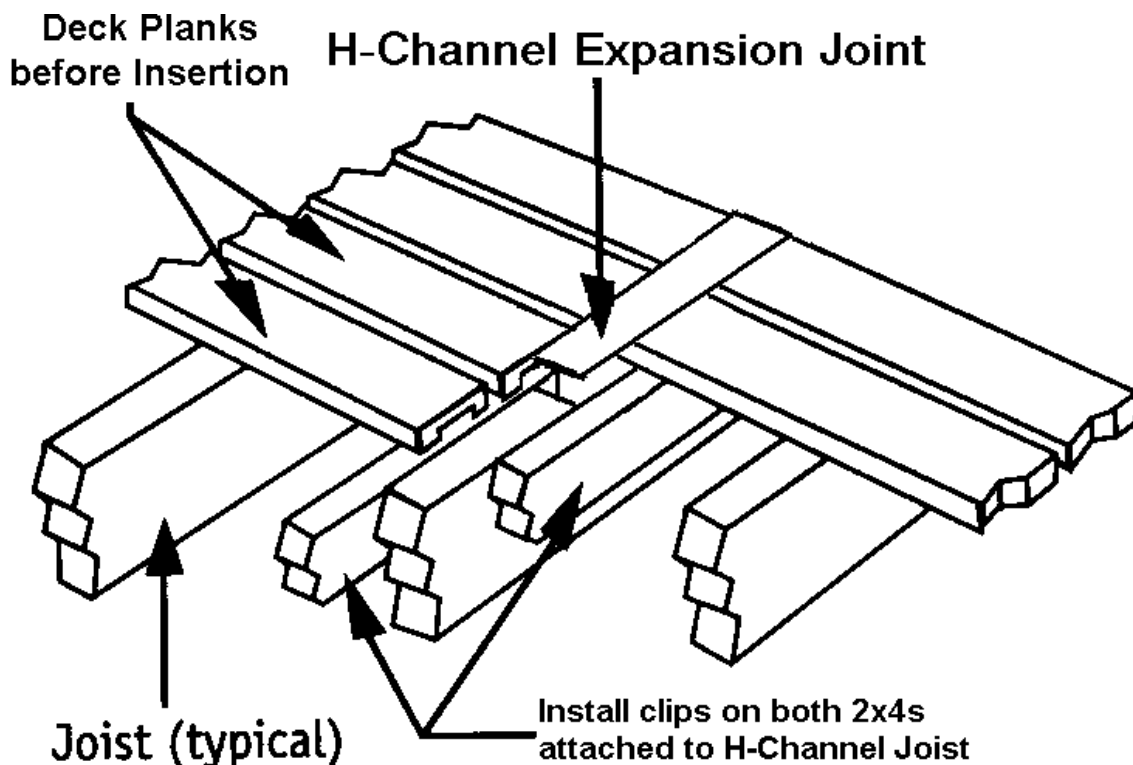

- When seating the deck planks into the H-channel leave a $\frac{1}{8}$ " gap between the end of the plank and the inside of the H-channel for expansion and contraction. This gap is necessary on both sides of the H-channel.

EXPANSION & CONTRACTION OF DECK PLANKS

- Lengthy deck planks exposed to temperature extremes may walk slightly as the planks expand and contract. To prevent this movement, several alternatives are available. Option 1: Use a rim joist (fascia board) trimmed with 2" nominal wood level to the deck top surface. Option 2: Metal 'L' strips can be installed on the centermost joist and attached with small stainless steel screws to the underside of the deck planks (1 screw/plank minimum). Option 3: A regular hex head #8 \times 1" stainless steel screw can be installed in the centermost joist of a long deck plank span (see drawing on page 1). This screw should be installed in the flat portion of the track (see below drawing) #8 \times 1" stainless steel screw 5/8" from the flange. Drill a corresponding 1/2" hole in the inner channel at the same location in the deck plank. When "snapping" the plank in place, insure the exposed screw head is captured by the drilled hole in the deck plank. The deck plank will remain in position at this point during expansion and contraction. **Note**: for Options 2 or 3, only attach directly to the deck plank in one location (typically centermost joist) per span.

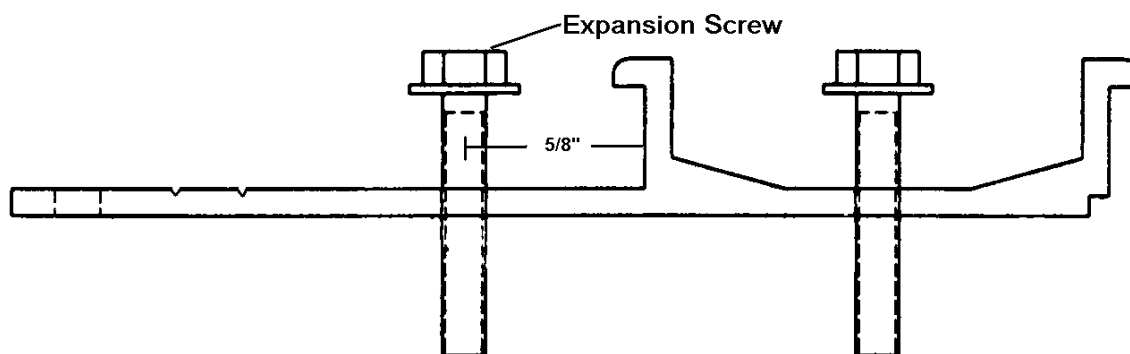

JOIST SPACING

- On new construction, it is recommended that 16" on center be used.
- Contractors often use 19.2" instead of 16" on center thus, saving time and material.
- When reconstructing an existing deck, a maximum of 24" on center is allowable depending on the load capacity to be placed on the structure.
- At no time, shall spans be greater than 24" on center.
- Pressure treated lumber is recommended for all exterior framing members. Treating or protecting joist top surfaces against moisture is also recommended, especially in moist environments.
- When deck planks are to be configured up to a 45° angle to joist, joist spacing must be no greater than 16" on center.

DECK REMOVAL PROCEDURES

- A cam removal tool is available for purchase which attaches to a standard $\frac{1}{2}$ " drive socket wrench. The cam portion is inserted in the elongated channel on the underside of the deck plank. When the cam is placed up in the channel next to the joist you then turn the cam 90° spreading the plank channel enough to remove the plank from the flange assembly.

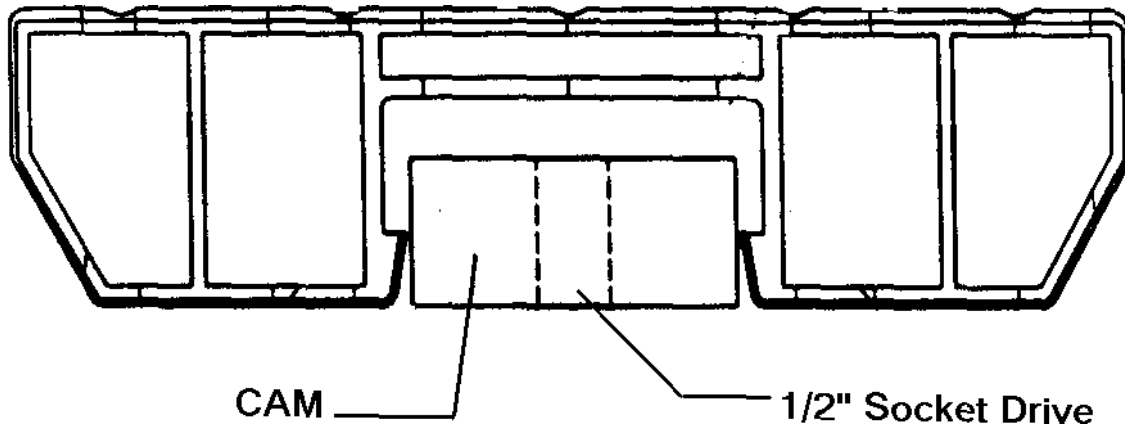

- The procedure is repeated down the length of the deck plank until all the flange assemblies have been disengaged from the deck plank.
- Removal of the deck plank is to be done with the cam removal tool only. Damage caused by other means or methods of removal will void the warranty.

STAIRS

- Stringer, horse, or carriage are terms used for the same cut out shape for stair treads.
- Stair stringer shall be made from 2X12 pressure treated lumber. The effective depth below the tread/riser notch should be a minimum of 3 $\frac{1}{2}$ " (check with local building codes). Stair stringers shall have a maximum span of 12" on center.
- Tread width for two full planks should be 12".
- Full planks are required at the nosing portion (front edge) of the stairs with the bottom side portion fully supported by the structure.
- There is $\frac{1}{2}$ " of an overhang created by the oblique angle of the deck plank.
- The 2' track can be used for stair track by cutting the track in half. You can then nip off the break lines located $\frac{1}{2}$ " in from the end of the two track segments which allows for a finished look at the nosing portion of the stair. The one 2' track member converts into two stair track.